



UNIFY SHIP MANAGEMENT PTE LTD

215 – PILOT CARD

Rev. 00 / 15.04.2025

Prepared: QHSE Dept.

Approved: DPA

ARRIVAL: MARSDEN POINT, NEW ZEALAND

SHIP'S NAME: BLUE ALEXANDRA

DATE: 06 FEB 2026

CALL SIGN V7A4707 YEAR BUILT 2005 DEAD WEIGHT 23793 TONNES

DRAFT AFT 8.10 m ft in. FORWARD 7.87 m ft in. DISPLACEMENT 30932 TONNES

SHIP'S PARTICULARS	
LENGTH OVERALL <u>177.0</u> m	ANCHORE CHAIN: (P) <u>11</u> shackles, (S) <u>11</u> shackles
BREADTH <u>28.40</u> m	(1 shackle = <u>27.4 m / 15 Fathoms</u>)
BULBOUS BOW <u>Yes</u>	

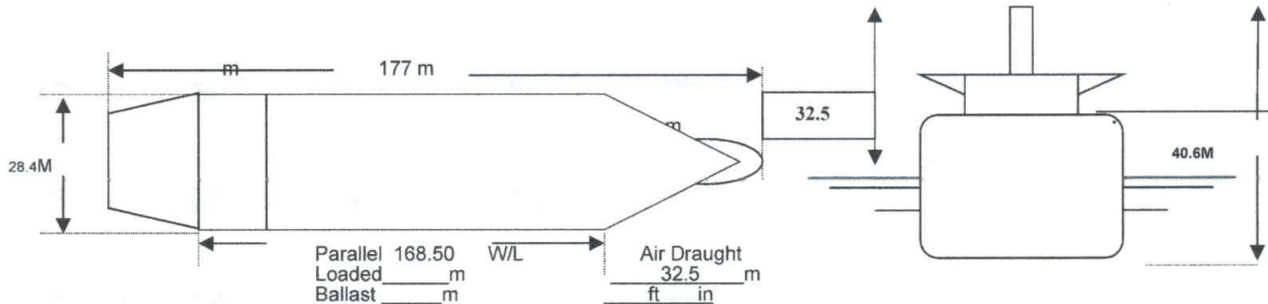

TYPE OF ENGINE: <u>Mitsubishi- 6UEC 52 LA</u> MAXIMUM POWER: <u>4,567 KW</u>			
MANOEUVRING ENGINE ORDER	RPM / PITCH	SPEED (KNOTS)	
		LOAD	BALLAST
FULL AHEAD	95	11.5	12.0
HALF AHEAD	85	10.5	11.0
SLOW AHEAD	55	7.0	7.3
DEAD SLOW AHEAD	40	4.5	5.0
DEAD SLOW ASTERN	40	TIME LIMIT ASTERN <u>1</u> MIN	
SLOW ASTERN	55	FULL AHEAD TO FULL ASTERN <u>7 MIN 30 SEC</u>	
HALF ASTERN	85	MAX. No. OF CONSEC STARTS <u>12</u>	
FULL ASTERN	95	MINIMUM RPM <u>40</u> <u>4.5</u> KTS	
		ASTERN POWER <u>69%</u> : <u>AHEAD</u>	

STEERING PARTICULARS	
TYPE OF RUDDER <u>BALANCE</u>	MAX. ANGLE <u>35</u> HARD-OVER TO HARD-OVER <u>24</u> SEC
RUDDER ANGLE FOR NEUTRAL EFFECT	
ENGINE POWER LIMITER (EPL) INSTALLED: <u>REMOVED</u> EPL MAX RPM: <u>110.5</u>	

CHECKED IF ABOARD AND READY				OTHER INFORMATION:		
ANCHORS	P & S			STEERING GEAR	2	
WHISTLE	YES			NUMBER OF POWER	2 POWER	
RADAR	YES	3cm	YES	10cm	UNITS OPERATING	1
ARPA	JRC/RADAR ARPA			INDICATORS: RUDDER	YES	
SPEED LOG	FURUNO	Doppler	YES	RPM/PITCH	RPM	
WATER SPEED	YES			RATE OF TURN	YES	
SEA OVER GROUND	YES			COMPASS SYSTEM	GYRO COMPASS	
DUAL AXIS	NO			CONSTANT GYRO ERROR		
ENGINE TELEGRAPHS	YES			VHF	YES 1 & 2 TYPE: JRC JHS 32B	
ECDIS	YES MAIN & BACK UP / TYPE JRC 9201S			ELEC. POS. FIX SYSTEM TYPE	GPS 1 & 2 TYPE JRC	
ECDIS SENSORS	GYRO	✓	SPEED LOG	✓	SHIP'S BITTS/BOLLARD SWL	YES 64 TONS
	GPS	✓	ECHO SOUNDER		OTHERS:	

Master: **CAPT. RECHIE N. LASTIMOSA**

Pilot:

